

LVDT

Inductive Position Transducer - Hydraulic Series



Series Hydraulic

- *position measurement in hydraulic cylinders of machine controls*
- *ranges 10...300 mm*
- *temperature*
-40...+150°C (sensors)
0...+60°C (external electronics)
- *pressure up to 400 bar*
- *output: AC/DC ($\pm 2,5$ V/ 0...10 V/ 4...20 mA)*
- *linearity 0,3%*
- *V4A flange (stainless steel)*
- *different flanges*
- *customised version available*

Description

The sensors are used in hydraulic cylinders with a maximum pressure resistance of up to 400 bar. They are especially suited to be employed in harsh industrial environments where a high electromagnetic tolerance is required. The sensor works nearly unaffected by electrical or magnetical fields.

This sensor enables a connection of the hydraulic cylinders and machine controls.

Customised versions with different measurement ranges and flange types are available.

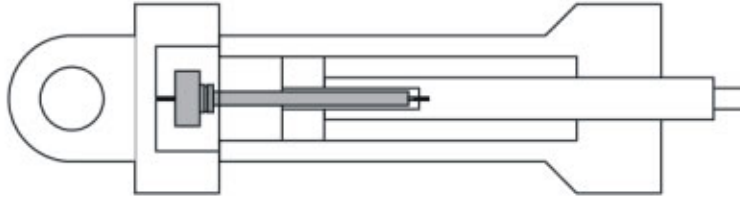

Technical Data

Sensor

measurement range	10...300 mm (see table)
linearity	±0,3%, ±0,8% for SM120/140/160
temperature range	-40...+150°C working temperature
vibration stability DIN IEC68T2-6	10 G
shock stability DIN IEC68T2-27	200 G/2 ms
connection	cable connection 4-core PTFE cable or connector output

Electronics

output signal (to be chosen)	0...20 mA, 4...20 mA (load <500 Ohm), 0...5 V, ±5 V (load >5 kOhm), 0...10 V, ±10 V (load >10 kOhm)
temperature coefficient	zero 150 ppm/°C, max. value 400 ppm/°C
ripple	< 20 mVeff
max. frequency -3 dB	300 Hz (Butterworth 5'th rang)
adjustment range	Offset ±20%, gain ±50%
isolation resistance	> 1 GOhm at 500 VDC
isolation stability	supply <> signal 500 VDC
power supply	24 VDC ±20%, (15 VDC ±20% optional, electrically insulated)
current consumption	<150/80 mA with/without load (supply 24 VDC), <300/100 mA with/without load (supply 15 VDC)
sensor supply	3 Vpp, 3 kHz
working temperature	0...+60°C
storage temperature	-20...+80°C
housing	meets UL94-VO
mounting	on DIN rail

Connection

Type with external electronics IMA

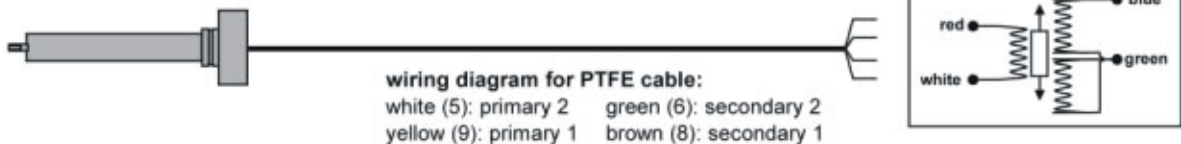

Type with cable electronics

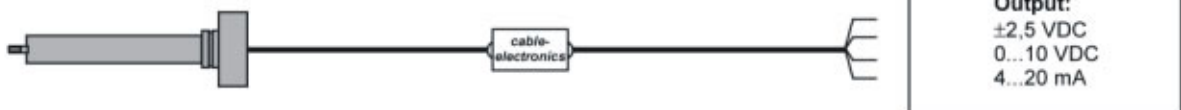

Pin description

IMA-connector	
pin A: primary 1	9
pin B: primary 2	5
pin C: secondary 1	8
pin D: secondary 2	6

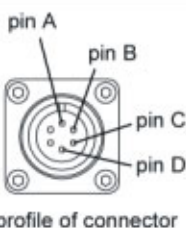

mating connector: AT3106F 14S-6S (please order separately)

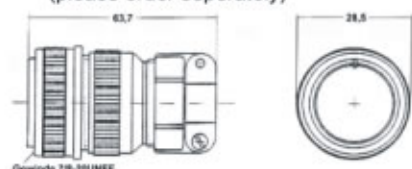

Dimensions

SM-HYD

SM-HYD-M

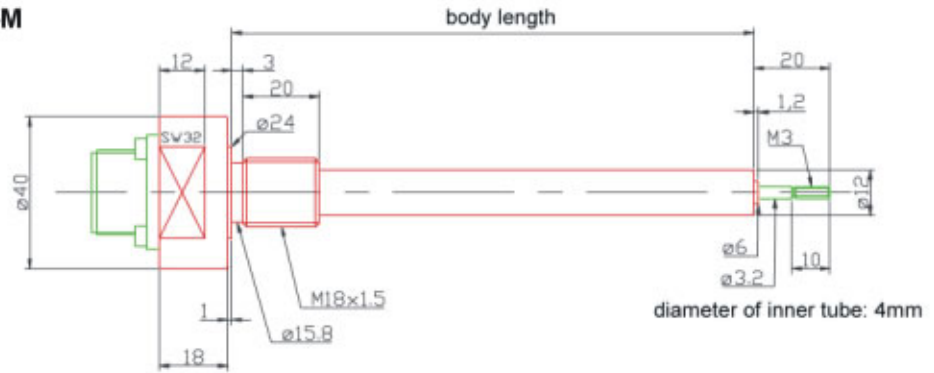
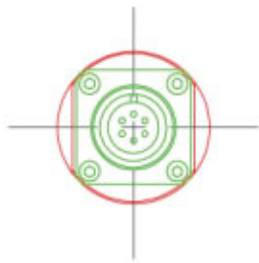

Range [mm]	type	body length [mm]
0...10 (±5)	SM10-HYD-M	74
0...25 (±12,5)	SM25-HYD-M	104
0...25 (±12,5)	SM25-HYD	137
0...50 (±25)	SM50-HYD-M	154
0...50 (±25)	SM50-HYD	207
0...100 (±50)	SM100-HYD-M	220
0...120 (±60)	SM120-HYD	227
0...140 (±70)	SM140-HYD	260
0...160 (±80)	SM160-HYD	336

Note for replacement of obsolete model PES:
 the model number of the PES-type indicated **half** the measurement range (values in brackets)
 PES12,5-2-VOEST is replaced by SM25-HYD-H-18-S

Dimensions

SL-HYD

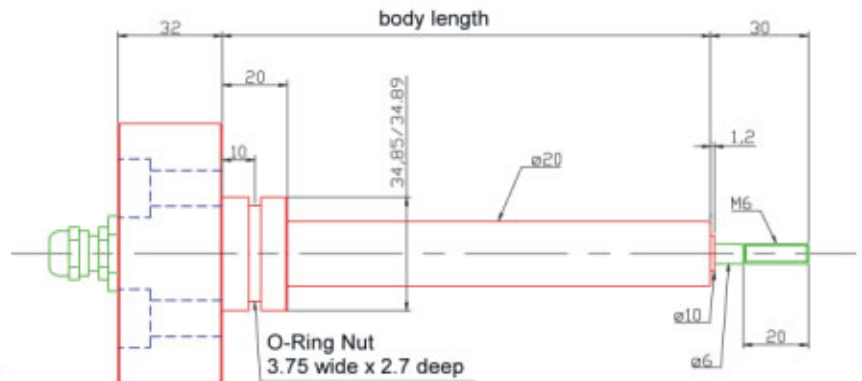
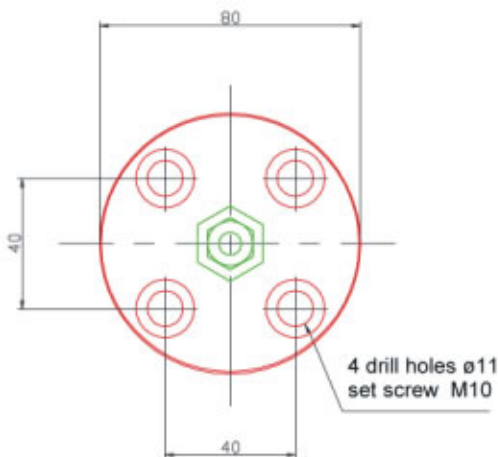

Range [mm]	type	body length [mm]
0...50	SL50-HYD	177
0...80	SL80-HYD	237
0...100	SL100-HYD	277
0...150	SL150-HYD	377
0...200	SL200-HYD	477
0...300	SL300-HYD	677

other measurement ranges on request

External electronics IMA



external electronics IMA
(for DIN-rail mounting)

Dimensions:

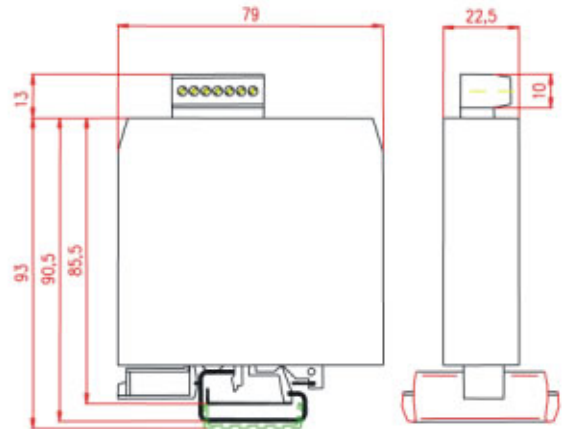

connection:

The external electronics IMA2-LVDT is designed to be installed in switch cabinets (DIN-rail mounting). The connection to the sensor is conducted as connector with screw clamps.

Please comply with the

For installation and wiring, please comply with the max. possible distance to frequency converters, their wiring and supply.

Do not wire sensor cables together with the supply of electrical drives or frequency converters.

wiring diagram for PTFE-cable (temp. Option H):

white (5): primary 2 green (6): secondary 2
yellow (9): primary 1 brown (8): secondary 1

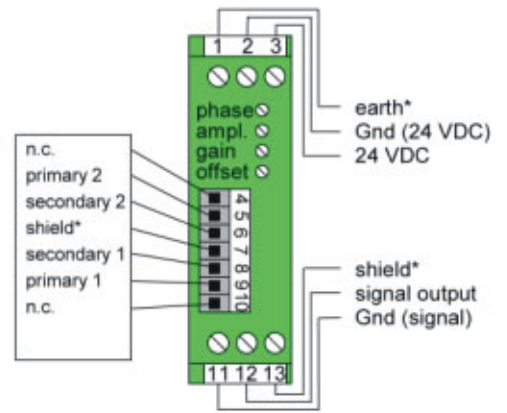

* clamps 1, 7 and 13 are internally connected

At harsh EMC environments, it is possible to install the electronics at a max. distance of 100 m in a switch cabinet. A twin twisted pair cable (4-cores, minimum cross section 0,5 mm²), single or double shielded, is to be used for the further wiring to connect the external electronics to the system. It is recommended to ground the shield in the switch cabinet near the electronics (do not ground at the machine / sensor). The sensor housing is grounded at the machine frame. To prevent interference, the cable length should not exceed 100 m.

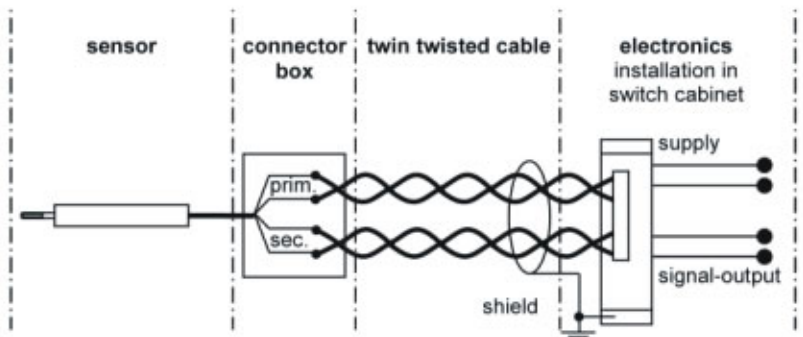

Adjustment of zero point and amplification of the electronics

Please note that zero point and amplification may shift for long cable lengths between sensor and electronics. Thus install the sensor with the according line length to the electronics and then adjust zero point and amplification.

1. Push rod entirely in - adjust offset:

Move the sensor to the zero point of the measuring range and set the offset potentiometer on 0mA, i.e. 0V for the output signal.

2. Push rod entirely out - adjust amplification:

Move the sensor to the mechanical end point (push rod moved out) and set the amplification potentiometer on 16mA/ 10V/ 5V for the output signal.

3. Adjust offset (4...20mA output)

Set the offset potentiometer on 20mA (+4mA) for the output signal.

Signal inversion

If an inverted output signal is required (20...4mA/ 10...0V/ 5...0V), then swap clamps 6 and 8 (secondary coil) on the external electronics.

Order code

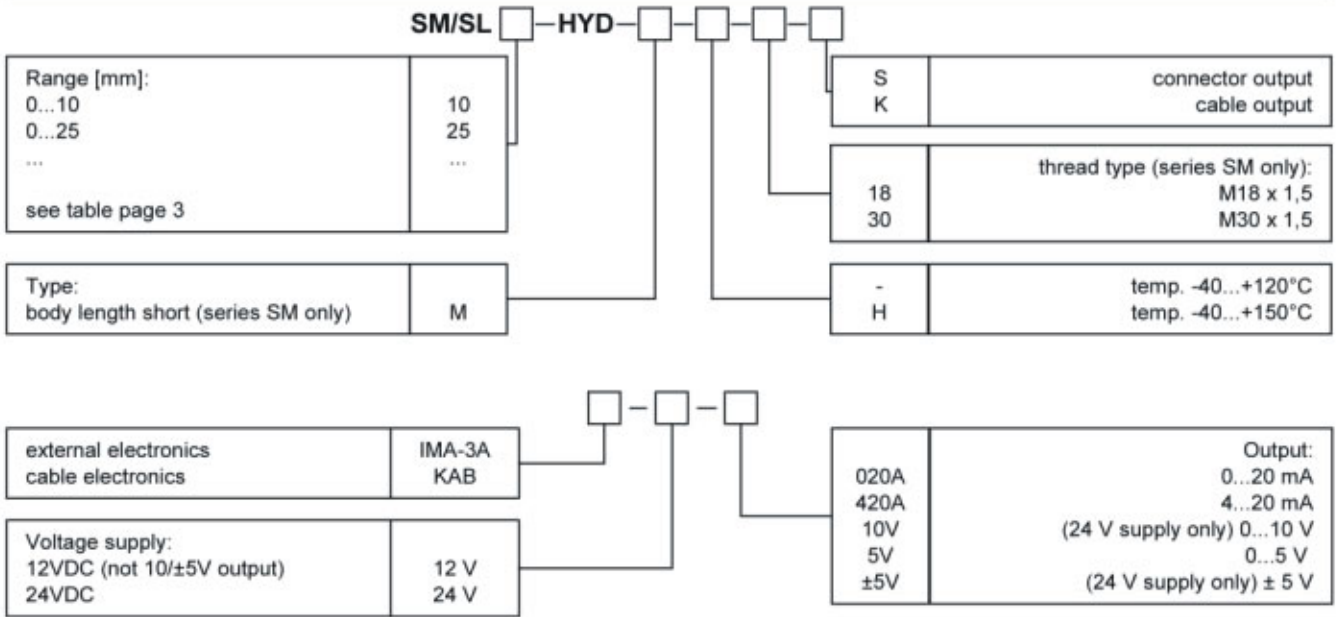

Price list

SM10-HYD-M	0...10 mm
SM25-HYD / SM25-HYD-M	0...25 mm
SM50-HYD / SM50-HYD-M	0...50 mm
SM100-HYD-M	0...100 mm
SM120-HYD	0...120 mm
SM140-HYD	0...140 mm
SM160-HYD	0...160 mm
SL50-HYD	0...50 mm
SL80-HYD	0...80 mm
SL100-HYD	0...100 mm
SL150-HYD	0...150 mm
SL200-HYD	0...200 mm
SL300-HYD	0...300 mm

Options

Mechanics:
 H increased temp. range 150°C
 420A/10V/05V integrated cable electronics

External electronics:
 IMA-3A output optional:
 4...20 mA/0...10 V/0...5 V/±10 V
 supply optional: 12 V/24 V

Please order separately:

connector cable (1,5 m Standard)
 each additional metre of PTFE-cable (250°C)
 (Option H)

mating connector AT3106F
 (for sensors with connector output only)

We reserve the right to alter the specification without prior notice

WayCon Positionsmesstechnik GmbH

e-mail: info@waycon.de

internet: www.waycon.de



DISTRIBUIDOR AUTORIZADO

www.ecos.eng.br

