

# LVDT

## Inductive Position Transducer



### Series SM $\varnothing$ 12 mm

- ranges 2...200 mm
- linearity 0,30% (0,20% on request)
- $\varnothing$ 12 mm, clamp- $\varnothing$ 8 mm h6
- output: AC, 0...10 V, 0...5 V, 4...20 mA, 0...20 mA,  $\pm$ 10 V,  $\pm$ 5 V
- with external or integrated cable electronics
- repeatability up to 1,5  $\mu$ m
- housing nickled steel
- temperature -40...+120°C (150°C on request)
- customised version available

**Technical data**

**sensor**

measurement range [mm]	0...2	0...5	0...10	0...25	0...50	0...100	0...200
linearity	0,30 % (0,20 % on request)						
types	sprung load (up to range 0...50), free core, push rod guided/ unguided						
protection class	IP65 or IP68 / 10 bar						
vibration stability DIN IEC68T2-6	10 G						
shock stability DIN IEC68T2-27	200 G / 2 ms						
supply voltage/frequency	3 Veff / 3 kHz						
supply frequency	2...10 kHz						
temperature range	-40...+120°C (150° on request, Option H; 200°C on request)						
mounting	ø8 mm h6 clamp diameter, or ø12 mm clamp brackets						
connection	4 core TPE-cable / PTFE cable (Option H) or M12-connection, coupling nut						
housing	nickled steel						
cable -TPE (standard)	ø4,5 mm, 0,14 mm <sup>2</sup> , non halogen, suitable for drag chains						
-PTFE (optional)	ø3,7 mm, 0,24 mm <sup>2</sup> , max. temp. 205°C						
max. cable length	100 m between sensor and IMA external electronics						
<b>sprung load (up to range 50mm):</b>							
spring force min/ max [N]	0,90	0,90	0,90	0,95	0,95		
max. cycles of tip at 1mm amplitude/s	55	50	50	35	20		
spring stiffness [N/mm]	0,29	0,20	0,12	0,06	0,04		
life time	> 10 Mio. cycles						
<b>free core / push rod:</b>							
max. acceleration of core / push rod	100 G						
life time	infinite						
weight (approx., without cable) [g]	36	42	47	59	85	136	238

**Electronics**

	<b>IMA external electronics (built-in)</b>	<b>KAB cable electronics</b>
output signal	0...20 mA, 4...20 mA (load <500 Ohm) 0...5 V, ±5 V (load >5 kOhm) 0...10 V, ±10 V (load >10 kOhm)	4...20mA (load <100 Ohm) 0...5 V, ±5 V (load > 5kOhm) 0...10 V (load >10kOhm)
temperature coefficient	zero 150 ppm/°C, max. value 400 ppm/°C	460ppm/°C
ripple	< 20m Veff	< 20m Veff
max. frequency	300 Hz/-3 dB (Butterworth 5'th rang)	-
adjustment range	Offset ±20%, gain ±50%	-
isolation resistance	> 1 G Ohm at 500 VDC	-
isolation stability	supply ↔ signal 500 VDC	-
power supply	24 VDC (18...36 V) or 15 VDC (9...18 V)	24 VDC (18...36 V) or 15 VDC (9...18 V)
current consumption	<150/80 mA with/without load (supply 24 VDC) <300/100 mA with/without load (supply 15 VDC)	65 mA (24 VDC), 140 mA (12 VDC)
sensor supply	3 Veff, 3 kHz	3,0 Veff (15...26V supply) 2,4 Veff (12...20V supply)
working temperature	0...+60°C	0...+60°C
storage temperature	-20...+80°C	-20...+80°C
housing	meets UL94-VO	aluminium
mounting	on DIN rail	none

The output signal is referring to the electric measuring range. If the sensor is operated outside the measuring range or the measuring range is exceeded, then the signal is also outside the defined range (i.e. >10V/ 20mA or <0V/ 4mA, in the graph: >100% or <0%).

Please keep this in mind for control systems with cable break detection lower than 4mA or for a maximum input voltage >10 V of measuring instruments. If necessary install the sensor **before** connecting to the plc.

Running direction of signal: If the push rod is moving into the sensor (e.g. sprung load pushed in), then the signal is reducing. If the push rod is moving out, then the output signal is increasing. The running direction of the signal can also be inverted.

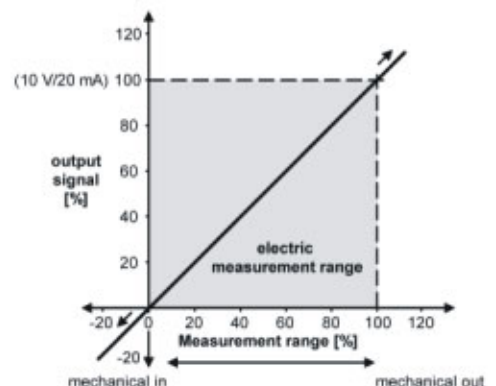

## Technical Dimensions

range (FS) [mm]	body length B radial cable/ connector [mm]	body length C connector M12 [mm]	core length D [mm]	push rod length E [mm]
0...2	64	67	22	54
0...5	70	73	25	60
0...10	80	83	30	70
0...25	110	113	45	100
0...50	160	163	70	150
0...100	260	263	120	250
0...200	460	463	220	450

Other ranges are available on request.

type: free core / unguided push rod

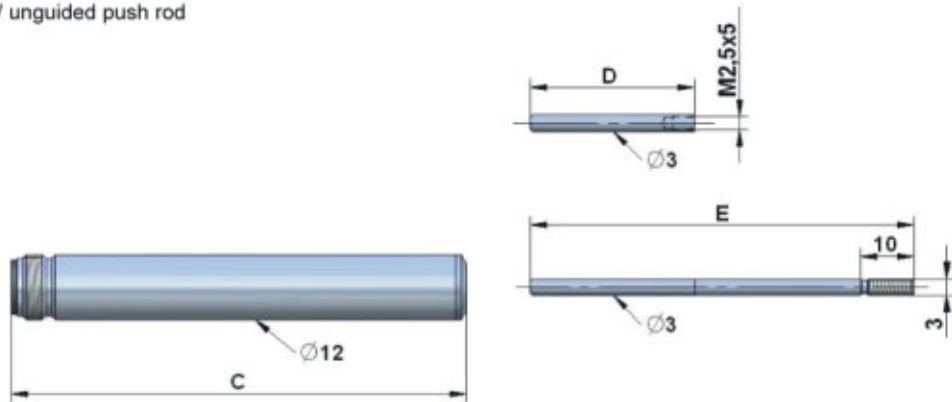

type: push rod guided

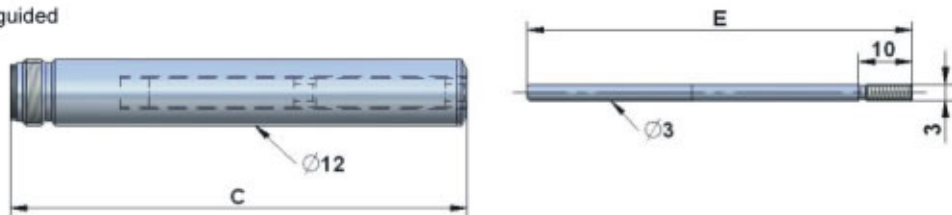

type: sprung load (up to range FS 0...50mm)

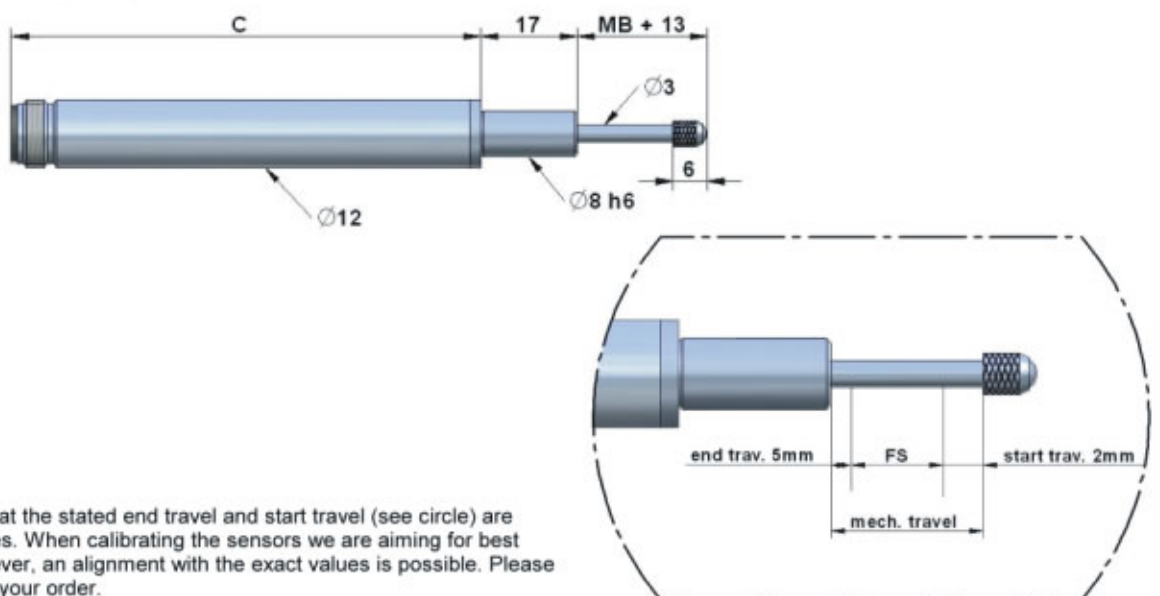

Please note that the stated end travel and start travel (see circle) are standard values. When calibrating the sensors we are aiming for best linearity. However, an alignment with the exact values is possible. Please specify that in your order.

## Cable outputs

### Axial cable output

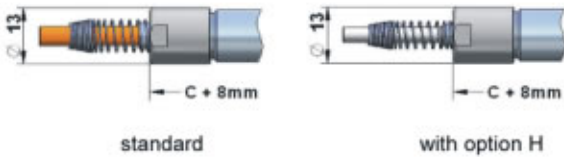

Sensors with cable output have a cable fitting and a spring for bend protection of the cable.

For installation, the bending radius should not be less than 3 times the cable diameter. The standard cable length is 2 m.

Instruments with option H for temperatures up to 150°C feature a PTFE cable.

### Radial cable/ connector output

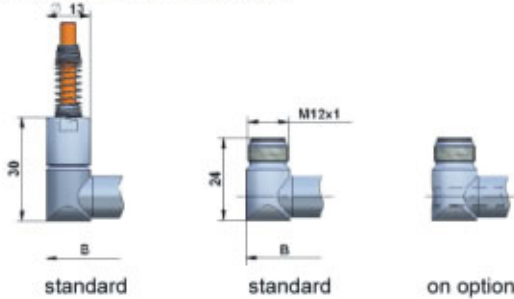

For normal application the sensors have a closed rear end body.

On request sensors can be supplied with a through hole. Please use this version for application at heavy dirt exposure. The movement of the push rod removes the dirt from the sensor and conveys it to the rear. The standard cable length is 2 m.

### Connector output (cable with straight or angular connector)

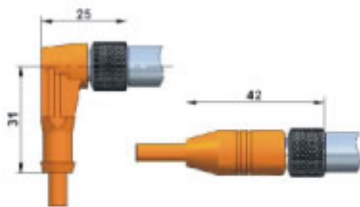

For sensors with connector output the cable has to be ordered separately. You can choose from a cable with a straight connector or with an angular connector.

The connector is protected from accidental removal by a threaded fitting (M12). The cable lengths are 2/ 5/ 10 m.

The connector pair has protection class IP65.

The total length of the sensor with connector is:  
body length of the connector M12 (see table) +20mm (angular connector)  
body length of the connector M12 (see table) +37mm (straight connector)

The following customised versions are available:

- specific measurement ranges (i.e. Xmm)
- pressure-tight instruments with built-in flange
- instruments for use underwater
- instruments with shortened body

### Connector pin assignment

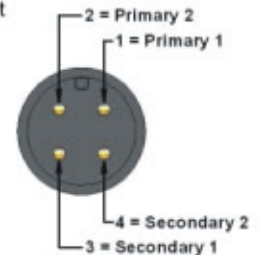

## Adjustment of zero point and amplification of the electronics

Please note that zero point and amplification may shift for long cable lengths between sensor and electronics. Thus install the sensor with the according line length to the electronics and then adjust zero point and amplification.

### 1. Push rod entirely in - adjust offset:

Move the sensor to the zero point of the measuring range and set the offset potentiometer on 0mA, i.e. 0V for the output signal.

### 2. Push rod entirely out - adjust amplification:

Move the sensor to the mechanical end point (push rod moved out) and set the amplification potentiometer on 16mA/ 10V/ 5V for the output signal.

### 3. Adjust offset (4...20mA output)

Set the offset potentiometer on 20mA (+4mA) for the output signal.

### Signal inversion

If an inverted output signal is required (20...4 mA/ 10...0 V/ 5...0 V), then swap clamps 6 and 8 (secondary coil) on the external electronics.



## AC-output

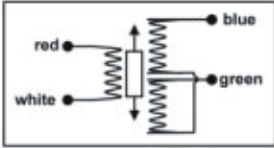

**wiring diagram:**  
 white (5): Primary 2  
 black (6): Secondary 2  
 brown (9): Primary 1  
 blue (8): Secondary 1

**wiring diagram for PTFE-connection:**  
 white (5): Primary 2  
 green(6): Secondary 2  
 yellow (9): Primary 1  
 brown (8): Secondary 1

## Cable electronics KAB



**cable length:**  
 electronics to sensor  
 1 m, 4 m or 9 m



If not specified otherwise the cable electronics is situated at 1 m from the end of the cable. On request in your order, however, the cable electronics is available at any distance.

**wiring diagram:**  
 brown: supply V+  
 blue: GND  
 black: output GND  
 white: output signal

**wiring diagram for PTFE-connection:**  
 yellow: supply V+  
 brown: GND  
 green: output GND  
 white: output signal

## External electronics IMA



external electronics IMA  
 (for DIN rail mounting)

**dimensions:**

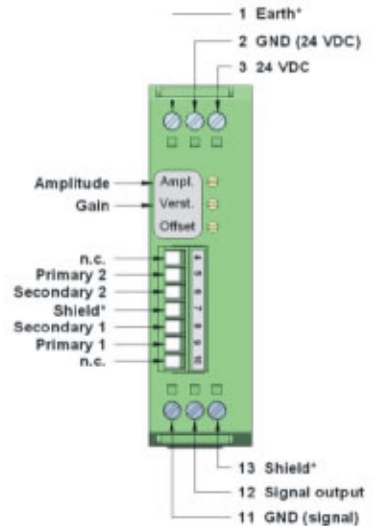
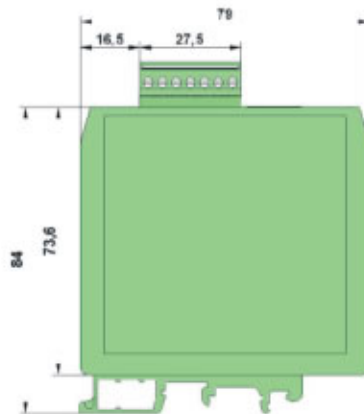

### Connection

The external electronics IMA2-LVDT is designed to be installed in switch cabinets (DIN-rail mounting). The connection to the sensor is conducted as connector with screw clamps.

\* Clamps 1, 7 and 13 are internally connected.

At harsh EMC environments, it is possible to install the electronics at a max. distance of 100 m in a switch cabinet. A twin twisted pair cable (4-cores, minimum cross section 0,5 mm<sup>2</sup>), single or double shielded, is to be used for the further wiring to connect the external electronics to the system. It is recommended to ground the shield in the switch cabinet near the electronics (do not ground at the machine/ sensor). The sensor housing is grounded at the machine frame. To prevent interference, the cable length should not exceed 100 m.

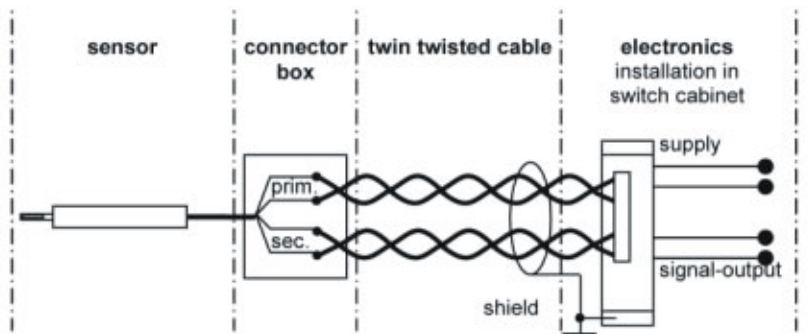

**Order Code**

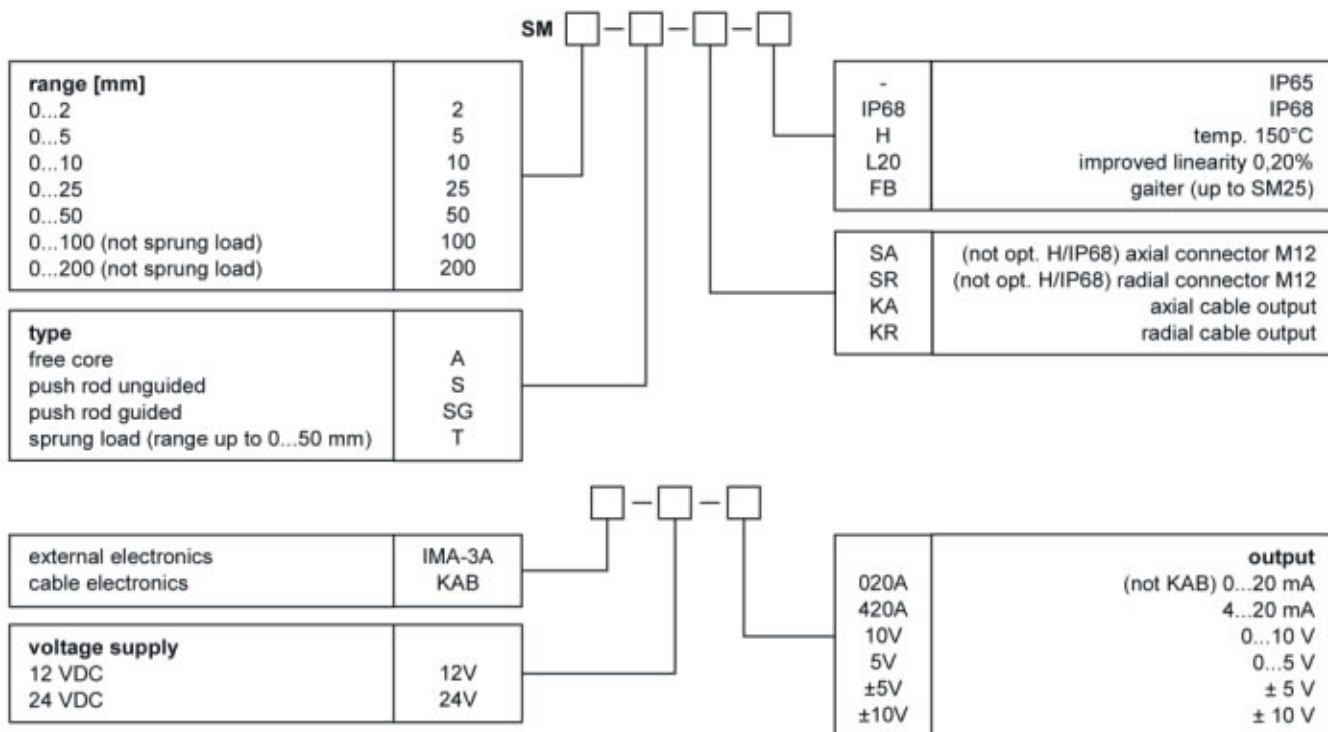

**Connector cable:**

**cable with straight connector M12 (SA)**

K4P2M-S-M12	2 m
K4P5M-S-M12	5 m
K4P10M-S-M12	10 m

**cable with angular connector M12 (SA)**

K4P2M-SW-M12	2 m
K4P5M-SW-M12	5 m
K4P10M-SW-M12	10 m

**fixed connector cable (2,0 m standard, KA, KR):**

additional metre of TPE-cable  
 additional metre of PTFE-cable (-H)

We reserve the right to alter the specification without prior notice

**WayCon Positionsmesstechnik GmbH**

e-mail: info@waycon.de

internet: www.waycon.de



**DISTRIBUIDOR AUTORIZADO**

www.ecos.eng.br

